



# H. I. N. G. E.

The N-Hance Guide Packet for Cabinet Door Hinges

# **H I N G E:** The N-Hance Informational Packet for Cabinet Door Hinges

## **TABLE OF CONTENTS:**

---

How Hinges Work.....	pg. 2
Installation.....	pg. 6
Navigating The Options.....	pg. 9
Good Hinge Placement.....	pg. 16
Executing Perfection.....	pg. 17
Final Recommendations.....	pg. 19

This guide packet aims to offer assistance, support, and clarity regarding the procedures involved in measuring, ordering, and installing new cabinet doors. Please note that not all potential issues related to hinges, or these processes, are exhaustively covered in this document. For any encountered challenges, we encourage you to reach out to the N-Hance Technical Training Specialists for prompt assistance. – **(435) 755-8490**

The provided information was written and compiled by Brennan Klinkowski, N-Hance Training Specialist, and is intended for the use of the N-Hance Technical Training Department.

# HINGE: The N-Hance Informational Packet for Cabinet Door Hinges

## How Hinges Work

There are some key functions that hinges have that allow them to operate which can be important to understand when measuring, ordering, and installing new cabinet doors. For example –

1. **Hinge Overlay:** Overlay refers to the measurement of how much the cabinet door overlays the cabinet frame, as shown in the diagram. The remaining exposed area of the frame, what the overlay does not cover, is referred to as the reveal. The placement of the hinge on your cabinet door does not determine your overlay. Rather, the hinge itself is what provides the overlay. Hinges are specifically designed to achieve the desired overlay you are measuring for. (Common hinge overlay sizes for face frame/compact hinges: 3/8", 1/2", 9/16", 5/8", 3/4", 1", 1-1/4", 1-5/16", 1-3/8", 1-1/2", 1-9/16")

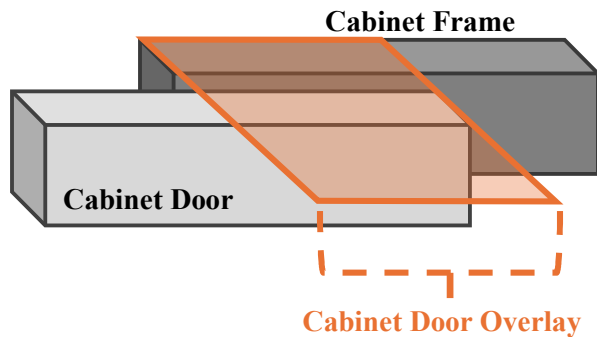

The remaining exposed area of the frame, what the overlay does not cover, is referred to as the reveal. The placement of the hinge on your cabinet door does not determine your overlay. Rather, the hinge itself is what provides the overlay. Hinges are specifically designed to achieve the desired overlay you are measuring for. (Common hinge overlay sizes for face frame/compact hinges: 3/8", 1/2", 9/16", 5/8", 3/4", 1", 1-1/4", 1-5/16", 1-3/8", 1-1/2", 1-9/16")

- **Face Frame Cabinets:** When measuring for new cabinet doors and you are changing the overlay size, record the width of each stile and rail of the cabinet boxes to know which overlay sizes you will be able to use, so that each door can fit and function properly. Using your measurements that you record; you can determine which overlay size is needed to achieve a “full overlay” look.

- **European Cabinets:** The rail/stile width for European cabinet boxes can range from 1/2" – 1-1/2", So always be sure to double check when

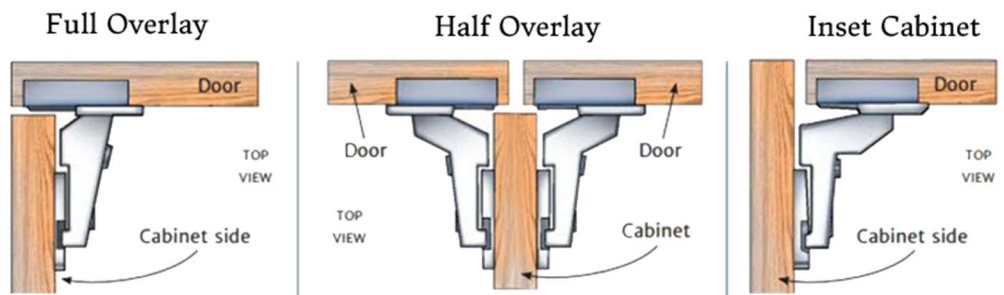

measuring. European/long-arm hinges, unlike face frame/compact hinges, are designed to achieve only 3 overlay options for European style cabinets (**Full overlay, half-overlay, or inset/recessed**). You can adjust your overlay by using the adjustments on the hinges themselves or by changing the thickness of the hinge plate. Hinge plates can vary in thickness; the thinnest being **0 millimeters**, then the sizes increase, all the way to even **9mm**. (**N-Hance Recommendation:** Use the hinge specification sheet of the brand of hinge you are using to determine what size of hinge plate is required to best achieve your desired overlay) – See examples on pages 2-3.

- **BORE HOLES:** The distance between the edge of the hinge bore hole to the outside edge of the door stile is called your TAB. The TAB thickness is typically **3 – 5 millimeters** (**N-Hance Recommendation:** 3mm. is the safest “rule of thumb”, however, we recommend following the specification guidelines of the hinge brand you are using to determine the minimum / maximum TAB distance required for the hinge you are using.) See examples on pages 3 - 4.

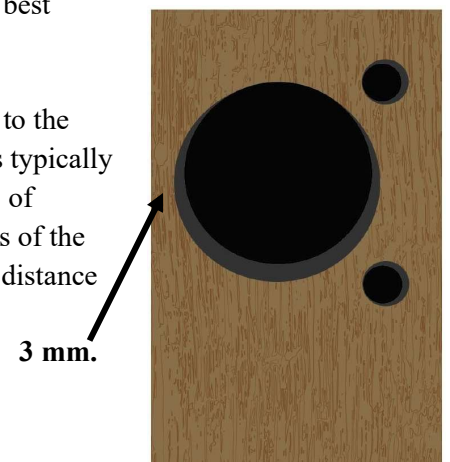

# HINGE: The N-Hance Informational Packet for Cabinet Door Hinges

## Instruction - RCS322 Hinges



### Overlay Factory Setting

K = Drilling setback  
H = Plate height

D = Overlay  
T = Door thickness

A = Reveal  
L = Door gap

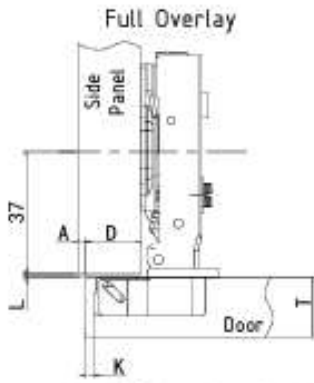

L = 15 (when plate setback at 37)  
H = 12 + K - D

D/K	3	4	5	6	7	
H	0	15	16	17	18	19
2	13	14	15	16	17	
4	11	12	13	14	15	

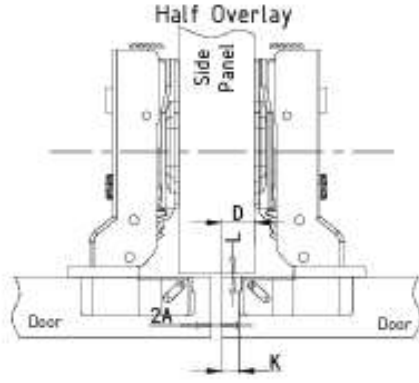

L = 15 (when plate setback at 37)  
H = 35 + K - D

D/K	3	4	5	6	7	
H	0	6.5	7.5	8.5	9.5	10.5
2	4.5	5.5	6.5	7.5	8.5	
4	2.5	3.5	4.5	5.5	6.5	

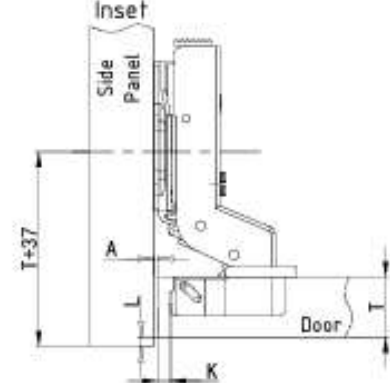

L = 0 (when plate setback at 37+T)  
H = -5 + K + A

A/K	3	4	5	6	7
H	0	2	1	0	
2	4	3	2	1	0
4	6	5	4	3	2

### Minimum Reveal \*

(with door edge r=1mm, based on factory setting)

A/K	14	15	16	17	18	19	20	21	22
3	0.3	0.5	0.7	0.9	1.2	1.5	1.8	2.2	2.6
4	0.3	0.5	0.7	0.9	1.1	1.4	1.8	2.1	2.5
5	0.2	0.4	0.6	0.9	1.1	1.4	1.7	2.0	2.4
6	0.2	0.4	0.6	0.8	1.1	1.3	1.6	2.0	2.4
7	0.2	0.4	0.5	0.8	1.0	1.3	1.6	1.9	2.3

\* Additional 0.5 needed for positive overlay adjustment

### Minimum Door Gap

(with door edge r=1mm, based on factory setting)

L/K	14	15	16	17	18	19	20	21	22
3	1.0	1.0	1.0	1.0	1.0	1.0	1.0	1.0	1.0
4	1.0	1.0	1.0	1.0	1.0	1.0	1.0	1.0	1.2
5	1.0	1.0	1.0	1.0	1.0	1.3	1.5	1.8	2.0
6	1.0	1.3	1.5	1.8	2.0	2.3	2.5	2.8	3.0
7	2.0	2.3	2.5	2.7	3.0	3.2	3.5	3.7	3.9

### Adjustments

Horizontal

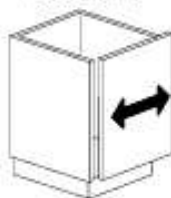

[-2, +2]

Vertical

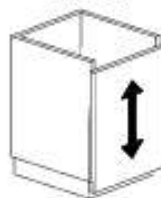

[-2, +2]

Depth

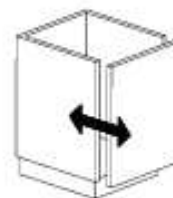

[-2, +2]

### Door Drilling

Min. 12



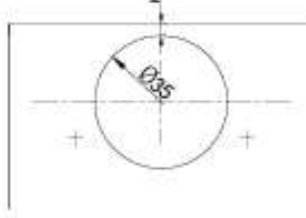

Wood Screw

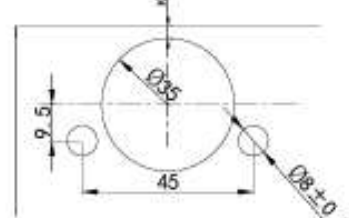

8mm Dowel

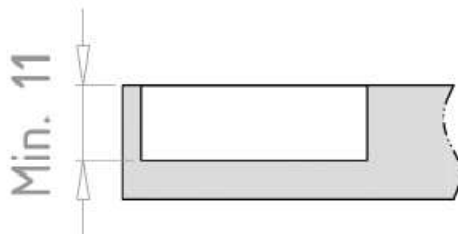
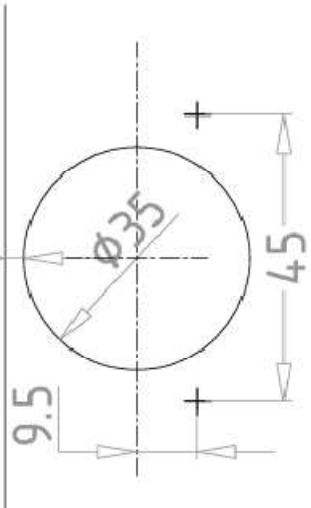
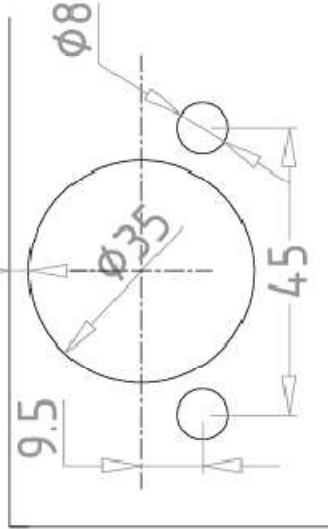

# HINGE: The N-Hance Informational Packet for Cabinet Door Hinges

<u>Drilling Depth</u>	<u>Wood Screw</u>	<u>8mm Dowel</u>
 <p>Min. 11</p>	 <p>Drilling Distance</p> <p>9.5</p> <p>Ø35</p> <p>45</p>	 <p>Drilling Distance</p> <p>9.5</p> <p>Ø35</p> <p>45</p>
<p>Unit: in mm unless otherwise stated</p>		
<p><b>Richelieu Hardware</b> </p>		
release Rev.	2022.08.31	Date
	By	Date
	SIZE	REV.
	DIM/NO.	REV.
		DO NOT SCALE DRAWING SHEET 1 OF 1

# HINGE: The N-Hance Informational Packet for Cabinet Door Hinges

- 2. Hinge Operation:** Whether the hinges in the cabinet door are European or face frame, they all have a similar push and pull motion when in operation. Hinges have pivot points, which allow the door to essentially rotate or pivot in place (**Face frame: 1 pivot point / European: 2 pivot points**). Face frame hinges have more “distance of travel” than European hinges because of their single point of motion. In the diagram below, it demonstrates how face frame hinges have more of a rotating motion than a pivoting motion. In the swinging motion of the door, the outside corner will travel approximately  $\frac{1}{4}$ ” towards the neighboring door. In order to account for this distance in your measurements, you will need  $\frac{1}{4}$ ” -  $\frac{1}{2}$ ” of space between any doors where the hinge side of the doors neighbor each other, so that both doors can operate freely without colliding into each other. Leaving  $\frac{1}{2}$ ” between doors is a good rule of thumb to follow if you are unsure about spacing. See other picture demonstration on page 7.

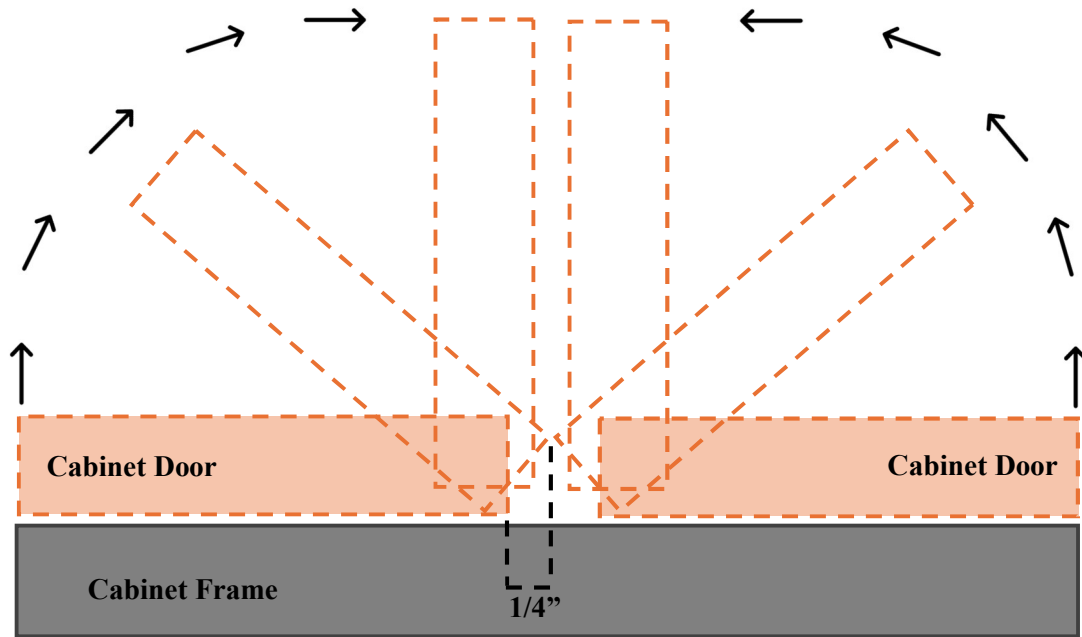

European hinges have two points of motion, allowing less than  $\frac{1}{8}$ ” distance of travel. European hinges allow the cabinet door to pivot in place by pushing the door out from the frame, while at the same time, pulling in the back inside edge, avoiding any binding. The movement of the hinge translates to the movement of the door. See the pictures below and on page 6.

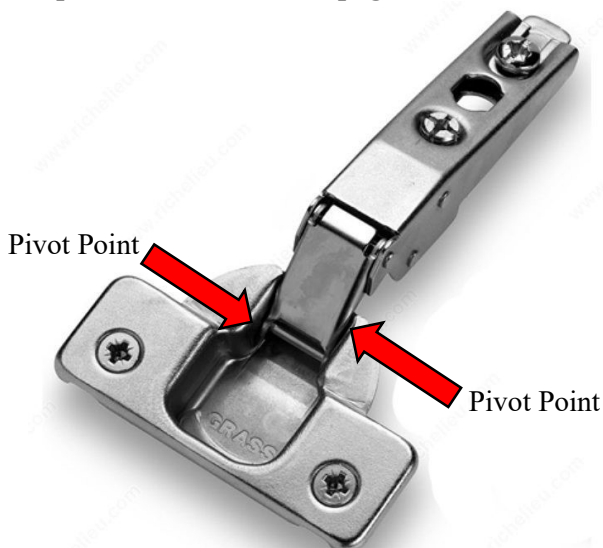

# HINGE: The N-Hance Informational Packet for Cabinet Door Hinges

## EUROPEAN / LONG-ARM HINGE



## FACE FRAME / COMPACT HINGE



The dual pivot point allows for more of a “pivot in place” motion, in the hinge, rather than a moving rotating motion.

## Installation

When installing new cabinet doors or hinges into the cabinet door and onto the cabinet box/frame, the options are simple, but which is best? Which overlay is best? How do I calculate my measurements accurately?

### 1. Dowel vs. Screw-on?

- If you are worried about whether dowel type hinges or screw-on type hinges are the preferred method of installation of the hinge to the cabinet door, don't be. Either method will work great for their intended purpose. There are pros and cons to both methods, so this can be a personal preference type of choice, but it's not enough to make an outstanding difference. Just be cautious of either stripping the wood when using screw-on type hinges or damaging the door or dowel when installing dowel type hinges.



### 2. Determining Your Overlay

- There are different methods of determining which overlay is best for your new cabinet door project. If you're simply replacing the existing doors with no sizing alterations, the existing hinges may have the overlay etched on them already or you can easily find the overlay by measuring the distance from the edge of the cabinet frame to the furthest edge of the cabinet door, WHEN CLOSED.
- When measuring for your desired overlay, first make sure that your stiles and rails are wide enough to properly fit neighboring doors without impeding each other. For example, if you are measuring for a 1/2" overlay, a width of 1-1/4" – 1-1/2" is the minimum amount required so that the doors can function properly without impeding each other. This will account for the 1/4" of travel that both doors undergo when opened (When using face frame/compact hinges). **See diagram on the next page, or on page 5.**

# HINGE: The N-Hance Informational Packet for Cabinet Door Hinges

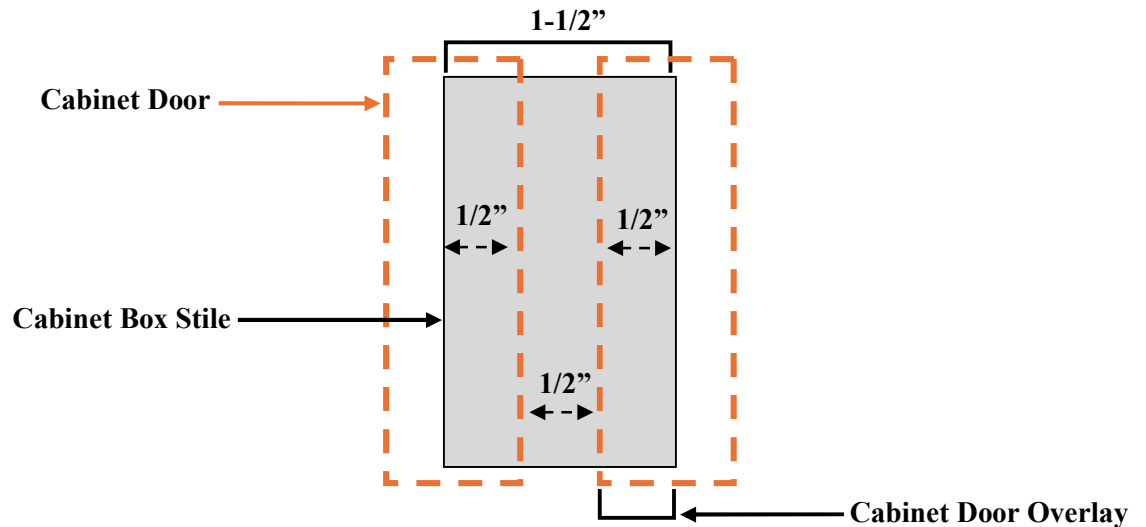

### 3. Calculating Your Measurements

- When changing the overlay, it can be tricky adding all the measurements together and making sure everything will fit perfectly. The best thing you can do to being successful in having accurate measurements is being consistent. We recommend measuring and adding your measurements together how you feel is best for you to be most accurate. If you are unsure, follow the **N-Hance recommended formulas** →

**Standard Doors & Drawer Fronts:**  $\text{Interior [Width or Height]} + \text{Overlay} + \text{Overlay} = \text{Door [Width or Height]}$

For your standard, “stand alone” door or any drawer front, the formula is the same. When you add your overlay to your measurement, you want to add it twice to ensure that each side of the door will overlay the cabinet the same, for both the height and width measurements. Be sure to double check to make sure that you have room on both the rails and stiles of the cabinet box so that your door will have enough room to operate properly. You may need to adjust the overlay for your width or height to properly fit over the cabinet box and not impede other doors or cabinet parts.

**Double Door Openings:**  $(\text{Interior Width} + \text{Overlay} + \text{Overlay} - 1/8") \div 2 = \text{Single Door Width}$

$\text{Interior Height} + \text{Overlay} + \text{Overlay} = \text{Door Height}$

When calculating your width for any double door opening, follow the same formula as if you were measuring for one large door, then subtract **1/8"** from your measurement to account for the **1/8"** reveal needed between the two doors. Once calculated, divide your measurement by 2 to account for both doors. That calculation will be your width for both cabinet doors.

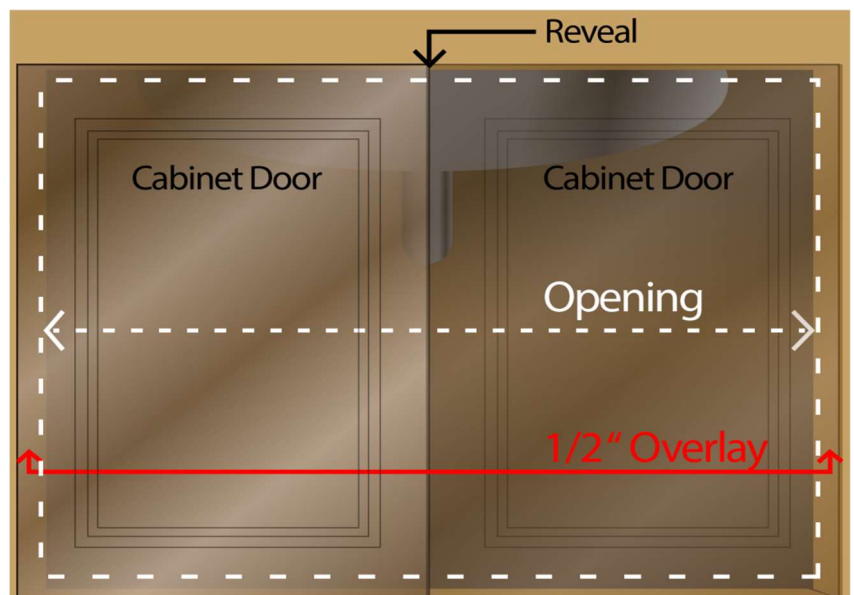

# HINGE: The N-Hance Informational Packet for Cabinet Door Hinges

**90° Corner Cabinets: (Interior Width + Overlay) – Door Thickness = Door Width**

**Interior Height + Overlay + Overlay = Door height**

When calculating your width for any 90° corner cabinet / lazy susan opening, there are a couple things to keep in mind. First, you only need to add your overlay to one side of the door, so do not add your overlay twice. Second, subtract the thickness of the door (It's usually 3/4" but always double check) to prevent the doors from binding. Follow that same formula to calculate the width for both corner doors. Subtracting 1/8" to account for the space between the doors is unnecessary in any corner cabinet scenario, for the reason that any adjustments for added space between the doors can be made by adjusting the hinges.



It is important to note that in order to achieve an overlay greater than 3/4", modification to the frame may be required. This is due to restrictions in hardware availability.

**45° Corner Cabinets: Interior Height + Overlay + Overlay = Door Height**

**Interior Width + 1/2" + 1/2" = Door Width**

When calculating your measurements for a 45° corner cabinet door, you can calculate your height measurement to the desired overlay you are trying to achieve, assuming you have the available room you need. When calculating your width, however, we recommend keeping the width at an overlay of 1/2" to minimize the chances of interference with neighboring doors and possible pinching or rubbing on the cabinet frame. Increasing or decreasing the overlay can depend on the profile of the door that you are installing and the total width of the cabinet stile itself.

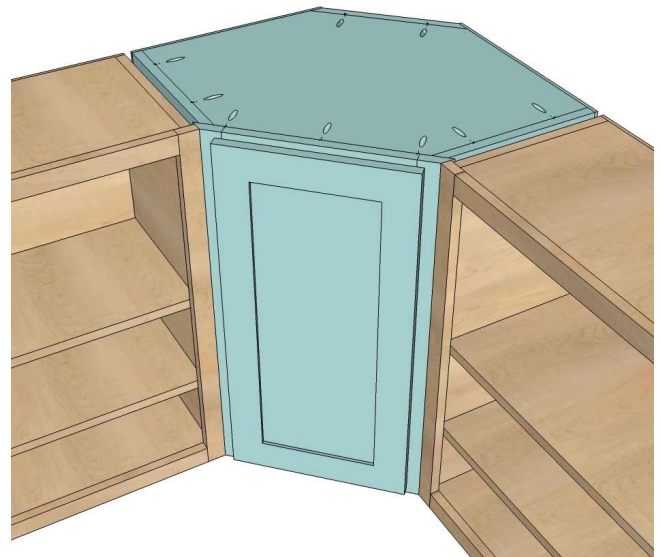

On the next page, a diagram shows how the overlay can impact the function of the cabinet doors. For example: If the cabinet stiles both have a width of 1-1/2", and you are trying to achieve an overlay of 1-1/4", the outside edges of both doors will interfere with one another, causing the edges to rub against each other or cause one of the doors, if not both of them, to not open fully. Resolving this hinderance requires that the corner cabinet door have a smaller overlay. The reason we do not recommend a larger overlay than 1/2" is to prevent any possible chances of cabinet door interference. There will be times where a larger overlay is possible but is not recommended.

# HINGE: The N-Hance Informational Packet for Cabinet Door Hinges

## 45° Corner Cabinet Diagram –

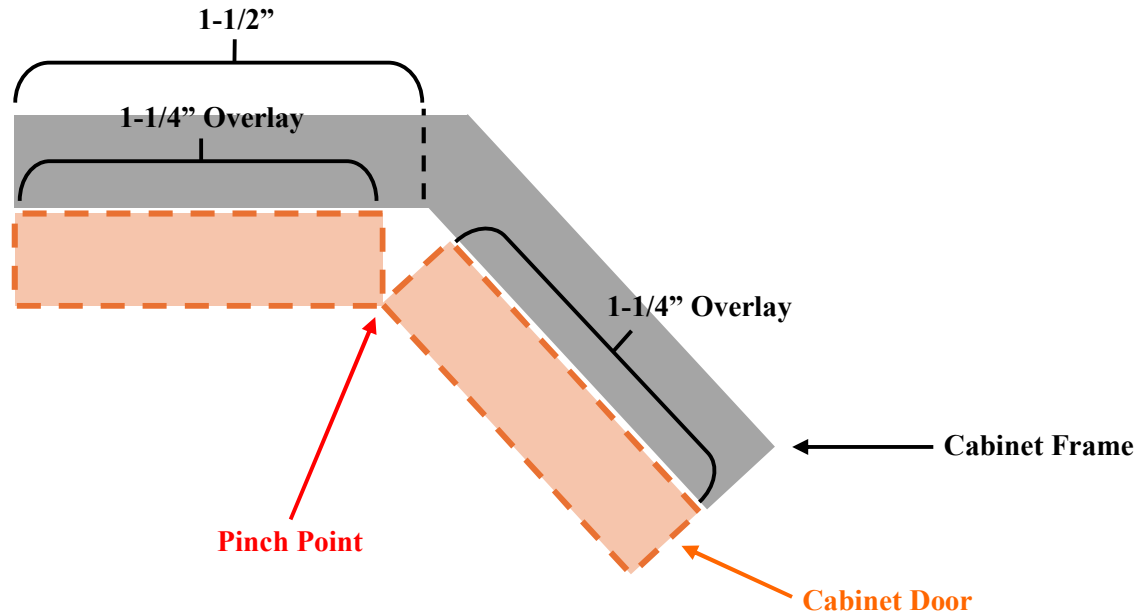

## Navigating The Options

The options for hinges can be quite extensive. “What hinges are best to use?” or “What brand is preferred?” are important questions, but this can be another personal preference type of solution. If you are unsure, here are the **N-Hance Recommendations:**

1. Recommended & Trusted Brands: **Blum / Salice / Richelieu**
  - Richelieu hardware will be the least expensive option due to the N-Hance/Richelieu vendor partnership.
  - Blum & Salice hardware can also be purchased at [Decore.com](http://Decore.com) & [Richelieu.com](http://Richelieu.com)
  - Recommended Richelieu Hinges:
    - **Face Frame Cabinets: RFF Series Hinge – Soft-Close**
      - Available Hinge Overlay Sizes: 1/2", 3/4", 1-1/4", 1-5/16", 1-3/8", 1-1/2"

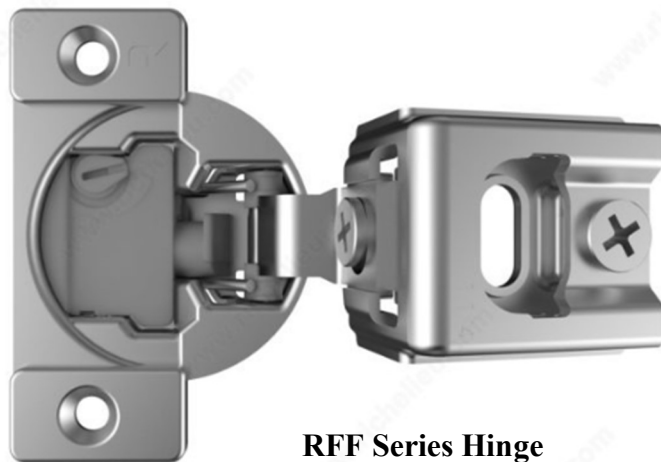

RFF Series Hinge

# HINGE: The N-Hance Informational Packet for Cabinet Door Hinges

- **Frameless Cabinets: RCS 105° Hinge – Soft-Close**
  - This hinge is also available in 95°.
  - Hinge Mounting Plate Required



**RCS 105° Hinge**



**RCS Mounting Plate for Face Frame Cabinet**

**Available Sizes:  
0 mm. / 3 mm. / 6 mm.**



**RCS Mounting Plate for European Cabinet**

**Available Sizes:  
0 mm. / 2 mm. / 4 mm.**

- **90° Corner Cabinet / “Lazy Susan” Cabinet**
  - Door to Door: RCS Bi-Fold Door Hinge
  - Door to Cabinet Frame: RCS 165° Hinge / Also available in 110°
  - Hinge Mounting Plate required.
  - **Note: 90° Corner Cabinet Hinges only come in 1/2” overlay sizes**



**RCS Bi-Fold Door Hinge**



**RCS 165° Hinge**

# HINGE: The N-Hance Informational Packet for Cabinet Door Hinges



**RCS Mounting Plate  
Door to Door Connection**



**RCS Mounting Plate for  
Face Frame Cabinet**

**Available Sizes:  
0 mm. / 3 mm. / 6 mm.**



**RCS Mounting Plate for  
European Cabinet**

**Available Sizes:  
0 mm. / 2 mm. / 4 mm.**

## 2. Screws & Other Components

- Screw Recommendations: It is important to have the correct screws and screw sizes for the correct intended uses. There are plenty of options to choose from, so this can be another personal preference type of choice. You can purchase screws from [Richelieu.com](http://Richelieu.com) or from your nearest hardware store. If you are unsure, below is a list of screw sizes that we recommend, along with a Richelieu screw recommendation sheet & display board of screws that you can purchase from *Richelieu* (pgs. 12 – 14).

### **N-Hance Recommendation –**

- Hinge to Door Connection: **1/2" – 5/8"**
- Hinge to Cabinet Frame Connection: **3/4" – 1"**
- Hinge Plate to Cabinet Frame Connection: **5/8" – 3/4"**

# HINGE: The N-Hance Informational Packet for Cabinet Door Hinges



## Hardware Screws



### Pan Head Phillips

Installation of One piece hinge  
Available in lengths 1/2" – 1"  
Most Common  
3/4" #10 Nickel Box of 1000  
- PPCN1034PRM1



### Flat Head Phillips

Installation of Slides and Euro Hinges  
Available in lengths 1/2" – 1"  
Several colors and screw sizes  
Most Common  
5/8" #7 Nickel Box of 1000 - FPCN758PRM1



### Replacement Hinge Dowels

8mm Plastic  
Bag of 100 - CP80213212



### Replacement Hinge Screws

7mm Zinc  
Sold each - FPBN612VPR



### Euro System Screw

7.2mm x 10mm Zinc  
Box of 1000 - MP660100180

For more information contact:  
Kevin Gavagan –  
Kgavagan@Richelieu.com

# HINGE: The N-Hance Informational Packet for Cabinet Door Hinges



## Decorative Hardware Screws



### Breakaway Truss screw

8-32 imperial thread  
Available in lengths 1 3/4" – 2"  
Multiple finishes  
Most Common  
2" Zinc Bag of 50 - 2905



### Breakaway Pan screw

M4 Metric thread  
Available in length 2"  
Zinc Finish  
Most Common  
2" Zinc Bag of 50 - 2805

## Installation and Assembly Screws



### Assembly / Installation

Flat Head w/Nibs, Type 17 point  
Available in lengths 1" – 3"  
Zinc finish – Combo drive  
Most Common Assembly / Euro install  
1 1/4" Box of 1000 - **FQCN17ZX8114PRM**  
Most Common Assembly / FF install  
2 1/4" Box of 1000 - **FQCN17ZX8214PRM**



### Pan Washer Double Cut

Standard cabinet installation screw  
Available in lengths 2 1/2" – 4"  
White or Zinc – Combo drive  
Most Common  
3" Zinc Box of 1500 - **PWQ172Z103PR**



### PWR DRIVE CAB

Premium cabinet installation screw  
Available in lengths 1 1/8" – 5"  
Black, White or Zinc – Square drive  
Most Common  
3" Zinc Box of 1500 - **FTKNC17Z103**

For more information contact:  
Kevin Gavagan –  
[Kgavagan@Richelieu.com](mailto:Kgavagan@Richelieu.com)

# HINGE: The N-Hance Informational Packet for Cabinet Door Hinges

Richelieu Screw Display Board (This not available for purchase from Richelieu)



1 800 619-5446  
www.richelieu.com

### FACE FRAME SCREWS

 WASHER FINE SQ DRY+LUBE 7x1-1/4" CCS12403 PWSW17P7114PR	 WASHER GRS SQ DRY+LUBE 8x1-1/4" CCS12357 PWSXC17P8114PR	 PAN COARSE SQ DRY+LUBE 7x1-1/4" CCS12272 FFS17P7114PR	 PAN FINE SQ DRY+LUBE 6x1-1/4" CCS12216 FFS2W17P6114PR	 PAN HILO SQ DRY+LUBE 7x1-1/4" CCS12275 FFSHL17P7114PR	 PAN CUTTER SQ DRY+LUBE 6x1-1/4" CCS12274 FFS2W17ZP6114PR
--	--	--	--	--	---

### DRAWER FRONT SCREWS

 PHILLIPS PAN WASHER ZN 8x1-1/8" CCS12218 PVMPCZ8118PR	 PHILLIPS T17 PAN WASHER ZN 6x1-1/8" CCS12719 PVMPC17Z8118PR	 COMBO PAN WASHER ZN 8x1-1/8" CCS13792 PVMQCZ8118PR	 COMBO PAN WASHER T17 ZN 8x1-1/8" CCS17549 PVMQC17Z8118PR
--	--	---	---



### INSTALLATION SCREWS

 RD WASHER COMBO ZINC 10x2-1/2" CCS12594 PWQ17Z210212PR	 RD WASHER ZINC WHITE 10x2-1/2" CCS12601 PWQ17Z2W10212PR
---	--

### FURNITURE SCREWS

 FLAT HEAD 8x1-1/4" CCS12280 FQCPX8114PR	 WASHER HEAD DRY+LUBE 8x1-1/8" CCS12295 PWQCP8118PR
--	---

### CUTTER SCREWS

 FLAT HEAD 8x1-1/4" CCS12416 FQCN17ZP8114PR	 WASHER HEAD DRY+LUBE 8x1-1/4" CCS12551 PWQC17ZP8114PR
---	--

### EURO & CONFIRMAT SCREWS

 POZI DRIVE NICKEL M6.3x30mm CCS17553 FPZESNM630PR	 PHILLIPS ZINC M6.3x10mm CCS19050 FFPESNM610PR
 POZI DRIVE NICKEL M5x40mm 7150402G	 POZI DRIVE NICKEL M6.3x10mm CCS13795 FPZESNM610PR

### HARDWARE SCREWS

 BREAK-AWAY SCREW ZINC 8-32 OR M4 THREAD 1 3/4" LENGTH LTCBA2832134	 MACHINE SCREW ZINC 8-32 OR M4 THREAD 1/2" - 2" LENGTH CCS12245 LTCMZ832114PR
---	--

### ASSEMBLY SCREWS

 EXTERIOR GRADE SQ NIBS NANO 7x2" CCS18747 FSCN17Z2A72PR	 PHILLIPS FLAT BLACK 8x1-1/2" CCS12600 FPCBPX8112PR	 PHILLIPS NIBS T17 ZINC 8x1-1/2" CCS12708 FPCN17ZX8112PR	 PHILLIPS NIBS T17 BLACK 8x1-1/2" CCS19284 FPCN17BPX8112PR	 SQUARE FLAT NIBS T17 ZINC 8x1-1/2" CCS17482 FSCN17Z8112PR	 SQUARE FLAT NIBS T17 BLACK 8x1-1/2" CCS18294 FSCN17BP8112PR	 COMBO FLAT NIBS T17 ZINC 8x1-1/2" CCS12152 FQCN17ZX8112PR	 COMBO FLAT NIBS T17 BLACK 8x1-1/2" CCS12153 FQCN17BPX8112PR
--	---	--	--	--	--	--	--

### HINGE & SLIDE SCREWS

 FLAT HEAD PHIL T17 ZINC 6x3/4" CCF0217384 FPZC17Z634PR	 FLAT HEAD PHIL T17 NICKEL 6x5/8" CCS26613 FPZC17LZ658PR	 FLAT HEAD PHIL ZINC 6x3/4" CCS12140 FPCZ634PR	 TRUSS PHIL ANT BRASS 6x5/8" CCS12360 TPCZ658ABPR	 LOW PROFILE WSHR PHIL ZN 8x1/2" CCS12361 TMPZ81/2PR	 TRUSS PHIL ZINC 8x7/16" TMPABZ8716PR	 TRUSS PHIL BLACK 8x1/2" TMPADP812PR	 TRUSS COMBO ZINC 8x7/16" CCS14101 TQCZ8716PR	 TRUSS COMBO BLACK 8x7/16" CCS12098 TQCBP8716PR	 TRUSS PHIL GRS ZINC 8x7/16" CCS14238 TMPZ8716PR	 PAN PHIL T17 NICKEL 10x3/4" CCS20267 FPCT17N1034PR
---	--	--	---	--	--	---	---	---	--	---

## HINGE: The N-Hance Informational Packet for Cabinet Door Hinges

- **Hinge Restrictors:** These small plastic pieces are angle restrictor clips that can be placed behind the arm of the hinge. These plastic restrictors limit the opening angle of the cabinet door. There are two different types, for either face frame hinges or European hinges. We recommend having these in your toolbelt to add to any doors that have the risk of being damaged or causing other damage when opened. This product can be found on [Richelieu.com](http://Richelieu.com)



European Hinge Restrictor – 89°



Face Frame Hinge Restrictor – 86°

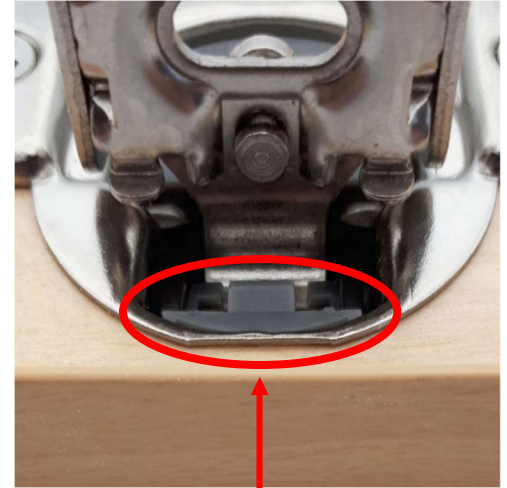

Hinge Restrictor – Face Frame Hinge

- **Soft-Close Adapters / Bumpers:** If soft-close hinges are not readily available or are out of your customer's budget, we recommend these easy-to-install, soft-close adapters. These adapters still provide the customer with a "soft-close" action in the door when closing. These adapters have a built-in adjustment to adjust the resistance of the mechanism to compensate for heavier or lighter cabinet doors. Below are a couple of different options for soft-close adapters that can be found on [Richelieu.com](http://Richelieu.com).



Face Frame:

BLUMOTION Door Bumper –  
971A



European:

BLUMOTION Door Bumper –  
973A

# HINGE: The N-Hance Informational Packet for Cabinet Door Hinges

## Good Hinge Placement

As previously mentioned, under the “**How Hinges Work**” section, hinges typically require **3 – 5mm**. TAB distance in order to operate and function properly. Additionally, it can be important to be aware of where your hinges are placed on the stile of the door. Typically, hinges are **3” – 4”** from the top or bottom of the cabinet door to the center of the bore hole, as shown in the image.

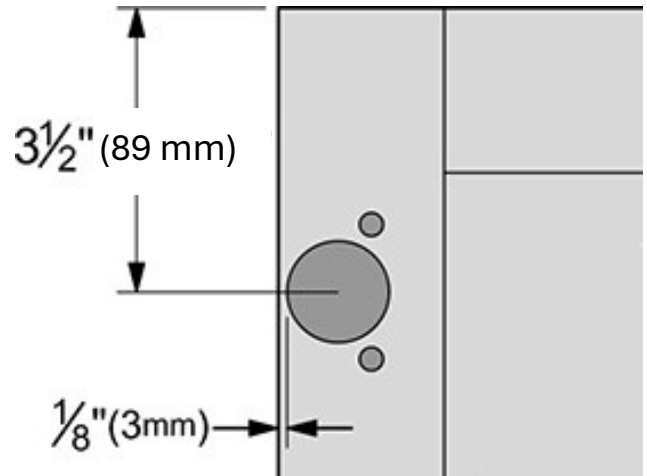

### 1. Does the distance matter?

- The standard bore hole distance from the top or bottom of the door ensures that the hinges will not interfere with the cabinet frame or other cabinet parts, as well as properly supporting the weight of the door. However, that does not mean that the bore hole cannot be moved. Slightly moving the placement of the bore hole, up or down, will not compromise the functionality of the door.

### 2. When would I move the bore hole?

- Realistically, there will only be a few instances where moving the placement of the bore hole on the door stile is necessary. When calculating your new door measurements in the home, check for things that could possibly interfere with the hinge of the cabinet door. For example, drawer pullouts can often be a forgotten deterrent to new cabinet door installations. If not taken into consideration, the drawer pullout can collide with the cabinet hinge, keeping the pullout from functioning properly.

In this case, the correct procedure would be to have the bore hole drilled just slightly higher or lower than the height of the drawer pullout, so that it can operate freely without harm. Doing this will not cause the door to function less effectively. This can also occur with lazy susan trays.



### 3. 3 – Hinge Rule

- Some cabinet doors require 3 hinges to evenly disperse and support its' own weight. It's important to take note of these doors when replacing, to make sure that your new cabinet door also has 3 hinge bore holes.

Not only does the third hinge help support the weight, all 3 hinges will help keep your larger/longer cabinet doors from bowing over time. We recommend adding a third hinge in place if the large cabinet door is solid wood or has a large glass panel. Adding a third hinge is more of a personal preference type of choice but does not negatively affect the function of the door itself.

# HINGE: The N-Hance Informational Packet for Cabinet Door Hinges

## Executing Perfection

Cabinet doors hinges can be adjusted to make your cabinet doors fit over or in the cabinet frame perfectly. Older style hinges, like these brass flush-mount hinges, most likely will not have any adjustments on them, but newer style hinges, like the Richelieu branded hinges shown before, can have up to 3 different adjustments on them. These adjustments allow you to alter how the hinge is positioned on the cabinet box, which in turn, alters the position of the cabinet door.



- 1. How It Works:** Newer style hinges will most likely have adjustment screws that allow it to move as needed. These screws are different than the ones used to attach the hinge to the cabinet door or the hinge to the cabinet frame. These smaller screws, usually located on the “arm” of the hinge, will adjust the position of the hinge when the screw is turned either clockwise or counterclockwise.
  - If the hinge or hinge plate allows, you can loosen the screws that attach the hinge to the cabinet frame, and slide the cabinet door up or down, as far as the hinges or hinge plates allow.



- 2. Hinge Adjustments:** Hinges can be adjusted side-to-side, up and down, and back and forth. It's important to know which adjustment screw will perform which action.
  - **Face-frame Hinges**

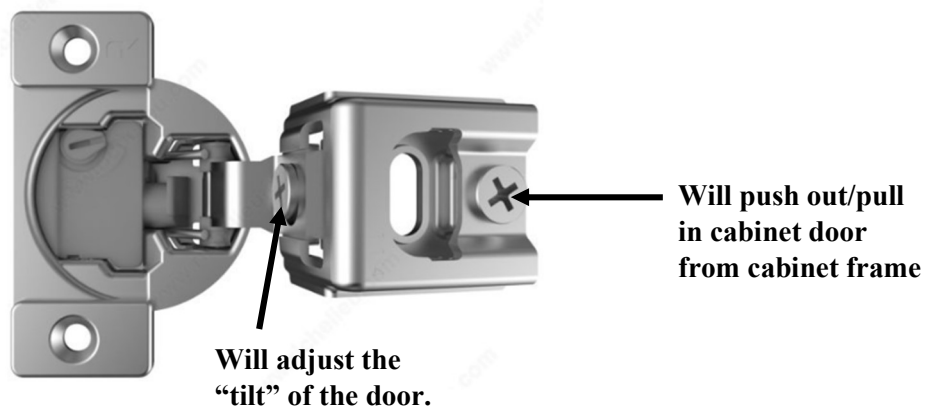

# HINGE: The N-Hance Informational Packet for Cabinet Door Hinges

- **Frameless Hinges**

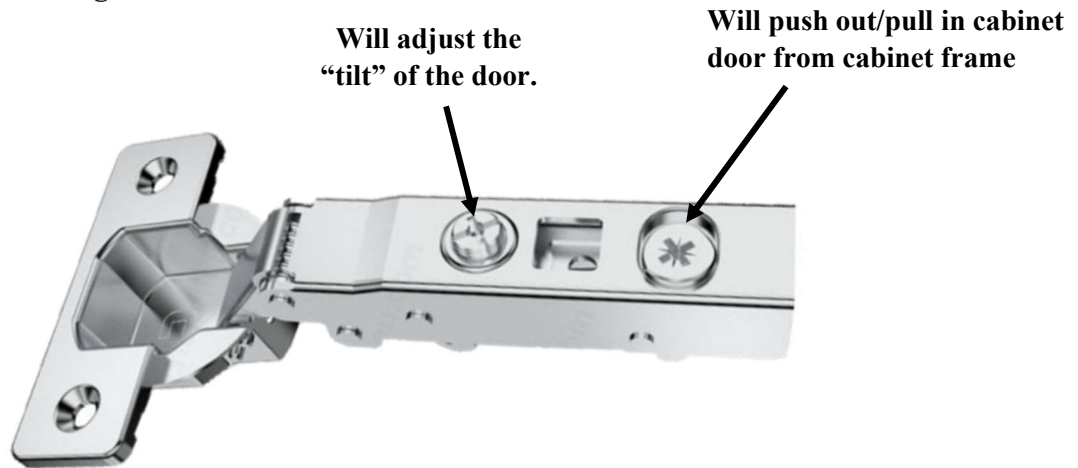

- **Applications:**

As you can see in this image, the two cabinet doors are misaligned. If there is not a center stile on the cabinet box, leaving a reveal no greater than  $\frac{1}{8}$ " is optimal. In this picture, the reveal between the doors is wider than  $\frac{1}{8}$ " at the top and tapers down to a narrower reveal. To correct this, use the adjustment screw closest to the front of the hinge to adjust the tilt of the door downward, rather than simply lowering the cabinet door entirely. Adjusting the tilt of the door will correct the misalignment of the reveal.

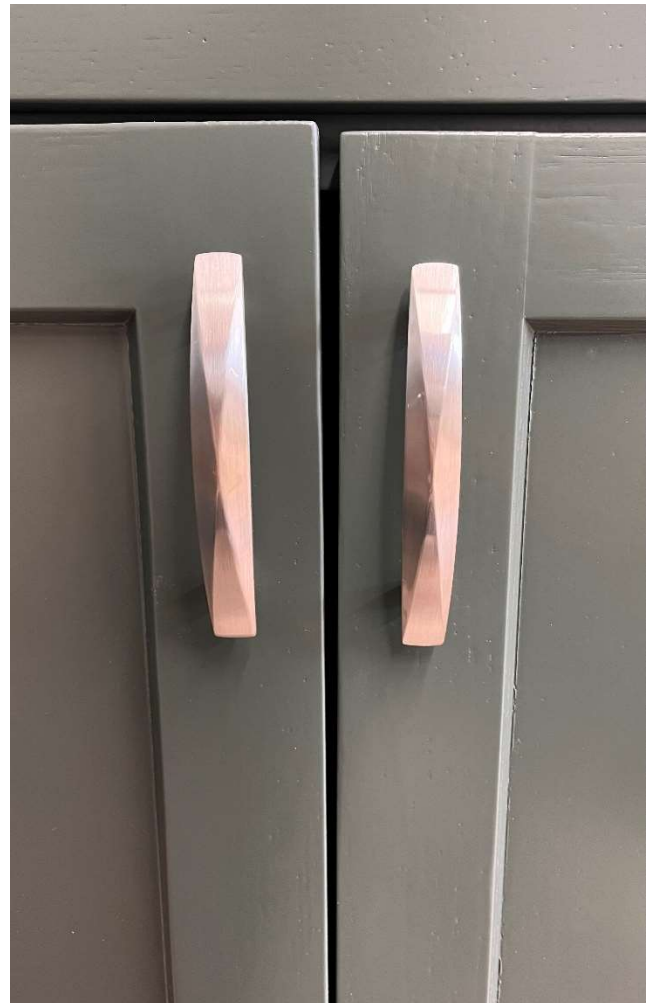

## HINGE: The N-Hance Informational Packet for Cabinet Door Hinges

- **Applications:**

In this image, the cabinet door protrudes past the drawer front sitting above it. The protruding edge of the cabinet door happens to be the hinge side, so, to achieve a seamless appearance the correct adjustment would be to use the secondary adjustment screw, furthest from the front of the hinge, to pull the back edge of the door inward, towards the cabinet frame. If the hinges were on the opposite side of the cabinet door, the correct adjustment would be to push the back edge of the door outward from the cabinet frame, causing the front edge to move inward.

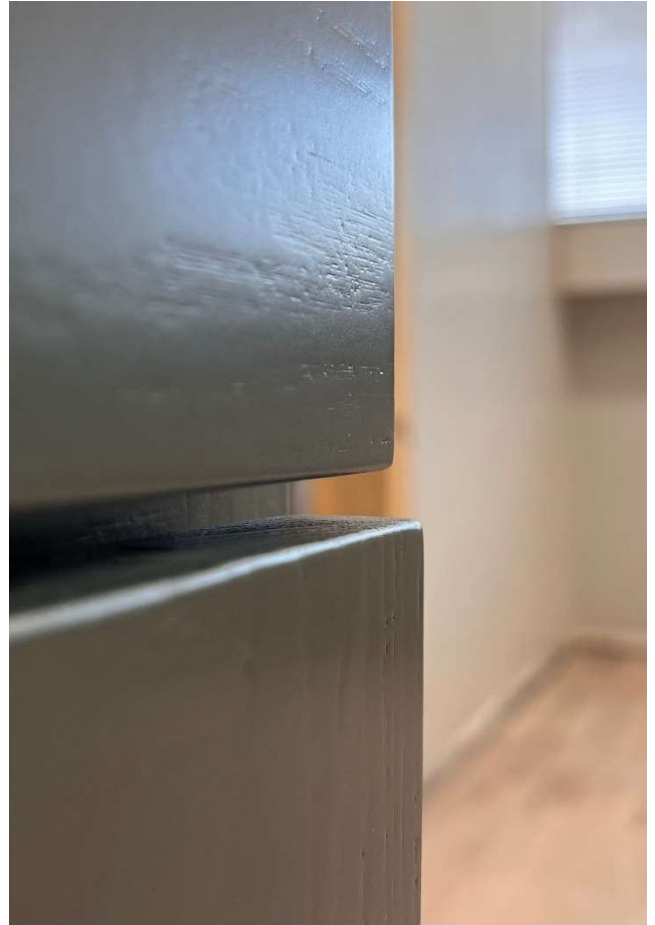

3. **Fine-Tuning: (N-Hance Recommendation)** When installing hinges and new cabinet doors, do not worry about making sure all the adjustments are correct before you install all the doors. Install all the doors first, then go through and do all your hinge adjustments. Doing this will show what adjustments are needed and where, rather than trying to perfectly adjust one door at a time, without reference. Once complete, then install your drawer fronts.
  - When adjusting cabinet doors, achieving perfect alignment with the cabinet frame can be challenging due to a number of factors such as, incorrect installation and/or the natural expansion and contraction of home walls, which can cause the cabinet boxes to shift or become unlevel.

Instead of endlessly striving for perfect alignment with the frame, which can be affected by the factors mentioned above, focus on aligning the bottom rails of upper cabinet doors and the top rails of lower cabinet doors together. This approach enhances aesthetic appeal and will present a more visually cohesive appearance to your customers, compared to aligning each door individually to the frame.
  - **N-Hance Recommendation:** Always use a screwdriver when adjusting the hinges to achieve small, incremental movements and to avoid stripping the adjustment screws. Using a drill/screw-gun can easily strip the screws if not careful and can be more difficult to make smaller adjustments.

# H I N G E: The N-Hance Informational Packet for Cabinet Door Hinges

## FINAL RECOMMENDATIONS:

1. When ordering hinges, we recommend ordering 10+ extra hinges of the next available size smaller and the next available size larger, just in case you are on a job site and run into complications with the doors not fitting properly.
2. Be sure to check the available room you have throughout the kitchen. Check the space that you have to work with near places around cabinet trim and molding, appliances, doors, walls, etc. The overlay can change throughout the kitchen so know what you're working with beforehand.
3. We recommend ordering hinges and other hardware through the preferred N-Hance vendors, *Decorative Specialties & Richelieu*, but if you have hinges or hardware available to you elsewhere, that is also acceptable.
4. When installing new cabinet doors, we recommend replacing all existing hinges with new, updated ones to enhance the overall appearance and provide a "like-new" feel for your customers' cabinets. However, there may be instances where retaining the existing hardware is necessary. If you choose to reuse the existing hardware, it is acceptable, provided that the hardware is in operable condition and the customer is aware. This decision is often based on personal preference or specific circumstances.
5. The hinge sizes depicted in the "**How Hinges Work**" section, do not include all available sizes that can be found. While many of the showcased hinge sizes are readily available from *Richelieu* and *Decorative Specialties*, additional unique sizing alternatives can be sourced from other suppliers, both locally and nationally.

# **H I N G E:** The N-Hance Informational Packet for Cabinet Door Hinges

The **N-Hance recommendations** presented in this document reflect the professional insights of the N-Hance Technical Training Department. These recommendations are offered for informational purposes and do not constitute mandatory requirements. They aim to provide foundational knowledge and insight to individuals seeking to understand, or further explore the processes involved in measuring, ordering, and installing new cabinet doors. Should you opt for alternative methods, that is also acceptable.

For any inquiries or clarifications regarding these recommendations, please reach out to the N-Hance Training Specialists –

**(435) 755-8490**